

industrial furniture



TRESTON®



ergonomics

FUNCTIONAL FURNITURE FOR PRODUCTIVE WORK

Treston is one of the leading industrial furniture suppliers in Europe, with professionals all over the world relying on its products and service. With our experience of several decades and our continuous product development we can offer our customers solutions that help them increase the productivity of their operations.

EXPERT SOLUTIONS FOR PROFESSIONALS

We focus on two product lines: industrial furniture and storage systems. As professionals we recognize our customers' needs and know how to develop the best products to meet these needs. In addition to high quality and durability we put a lot of effort into product ergonomics and design. Due to the flexibility of our production we can offer customized solutions as well. We produce workbenches, storage cabinets, tool trolleys, work chairs etc. for the various needs of our customers. Our versatile modular product range can be used to build comprehensive, functional work stations for all industries and company sizes. We also produce furniture with ESD protection. We offer storage solutions for production facilities as well as warehouses and shops.

ASSURED QUALITY AND RELIABLE SERVICE

Reliability, which is embedded in all our operations, is the cornerstone of our client centered work. It means our customers can have total confidence in the durability, functionality and high quality of our products. It also means listening to our customers, understanding their industry-specific needs, maintaining continuous co-operation and offering flexible service at every stage of the delivery. Having our own production facilities is one of the most significant factors contributing to the reliability of our products. Through centralizing the production in our own factory we can ensure the best possible quality control. Treston is an ISO 9001:2000 registered company, and our industrial furniture has the quality approval (TÜV).

PACKAGING

Each TRESTON workbench and trolley comes in an individual carton with all necessary fittings and instructions. Modular elements of workbenches are securely packed with styrox protection. Very easy assembly with full instructions included.

COLOURS

Colours reproduced here are as accurate as print techniques allow.

light grey
RAL 7035



grey
RAL 7045

design



flexibility

contents

Adjustable workbenches WB • height adjustment by allen key, retractable handle, by electric motor	4-7
Workstation WS • height adjustment by allen key, retractable handle, by electric motor	8
Workbenches TP/TPH • height adjustment by allen key	9-11
Moveable benches CTR/SAP	5, 10
Heavy duty workbenches HDB/HDBL	12-13
Steel cabinets ML	14
Light steel cabinets LMC	15
Computer accessories, bottle holder	16
Perforated panels, cupboard unit, hooks	17
Energy panels WJK/CJK/TJK	18
Lighting units	19
Universal trolley WTR	20
Adjustable trolleys TRTA	21
Industrial trolley IT	22
Assembly trolley HAT Workshop trolley RV	23
Chairs TTJ/KT/TJAS	24
Packing stations PPH	25
Industrial office screen system P	26-27

adjustable workbenches WB



The new generation WB workbench has been designed for use in demanding assembly environments. The concept is one of simplicity and good ergonomics, allowing each bench to be adapted to a variety of tasks. Electric motor, manual hand crank or allen key height adjustment cater for standing or seated users, while the generous worktop depth and broad accessory range ensure that everything is within easy reach. Another feature of this new design is the flush bench footprint; benches can be placed side-by-side, back-to-back, or right up against walls with no unnecessary gaps. You can design your workstation to fit your needs perfectly.



1. Workbench WB

Worktop height is adjusted by manual allen key, retractable handle or electric motor between 700...1100 mm. The adjustment system in both cases utilises interlocking aluminium profiles, providing a strong, rigid frame. Steel frame parts are epoxy powder coated light grey paint, RAL 7035. Worktops are of 25 mm laminated particle board, adjustable feet are provided for fine levelling.

Allen-key adjustable bench. Load capacity 250 kg equipment static u.d.l.

Code	Worktop mm
WB 811	800 x 1073
WB 815	800 x 1500
WB 818	800 x 1800



Handle adjustable bench. Load capacity 200 kg equipment static u.d.l. A cable tidy is included.

Code	Worktop mm
WB 811 C	800 x 1073
WB 815 C	800 x 1500
WB 818 C	800 x 1800

Electric adjustable bench. Adjustment speed using the motor is 19 seconds min. to max. Load capacity 200 kg equipment static u.d.l. A cable tidy is included.

Code	Worktop mm
WB 811 EL	800 x 1073
WB 815 EL	800 x 1500
WB 818 EL	800 x 1800



2. Side worktop WB 804 ST

This new side worktop can be installed on either the right or left hand side of a WB bench to increase the surface area. Installation can be either at the same height, or lower than the main worktop with the brackets provided. Load capacity for this side worktop is 50 kg, and it is suitable for all WB models in the range. Dimensions 800 x 400 mm.

3. Corner worktop WB 1212 CT

A corner worktop can be used with two WB benches to create a 90 deg. angle setup. This unit consists of a worktop and all necessary components. It requires no additional leg frames, simply mounting to the standard benches with the brackets provided. Load capacity for this worktop is 50 kg. Dimensions 1153 x 1153 mm.

Not suitable for WB EL or WB C versions.



4. Moveable bench CTR 705

Height adjustment with allen key between 690..990 mm. A lower shelf is integrated. Steel frame parts are epoxy powder coated light grey paint, RAL 7035. Swivel castors Ø 100 mm of which two are braked. Load capacity 75 kg/shelf static u.d.l.

>>>

adjustable workbenches WB

>>>



Modular accessories are available to provide ergonomic storage and presentation of parts and equipment. The upper section can be used as one module, or divided into two modules horizontally using the AKK accessory frame.

Accessories

- steel parts are epoxy powder coated light grey paint, RAL 7035.
- shelves are of 25 mm laminated particle board
- WB 811 benches can be fitted with size 100 accessories in one module
- WB 815 benches can be fitted with size 70 accessories in two modules
- WB 818 benches with one size 70 and one size 100 module.

1. Upright profiles AL2X-W

Needed for mounting accessories to benches. Includes 2 vertical and 1 horizontal profile. With 3 cable clips (CC8).

Code	Dims mm	Suitable for
AL2X 110 W	1063 x 900	WB 811
AL2X 150 W	1489 x 900	WB 815
AL2X 180 W	1789 x 900	WB 818

2. Accessory frame AKK

The accessory frame divides the space between the upright profiles into 2 modules. AKK frame includes 1 vertical and 1 horizontal profile. Useable height 500 mm.

Code	Dims mm	Suitable for
AKK 150	690 + 690	WB 815
AKK 180	690 + 990	WB 818

3. Shelf ALH

Height adjustable shelf. 25 mm laminated particle board. Load capacity 50 kg.

Code	Dims mm	Suitable for
ALH 110	310 x 1073	WB 811
ALH 150	310 x 1500	WB 815
ALH 180	310 x 1800	WB 818

4. Adjustable shelf ASH

Continuous adjustment for depth, height and angle. Shelf of 25 mm laminated particle board. Lipped front edge. Load capacity 35 kg static load. Mount on accessory frame.

Code	Dims mm	Suitable for
ASH 70	400 x 660	WB 815/818
ASH 100	400 x 960	WB 811/818

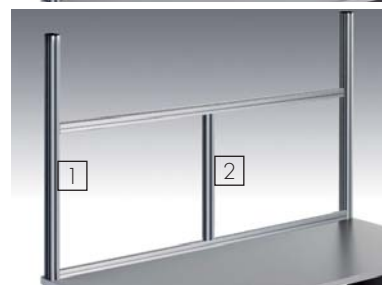

5. Bin profile BP

Aluminium profile for TRESTON stacking and picking bins. Mount on accessory frame.

Code	Dims mm	Suitable for
BP 70	length 685	WB 815/818
BP 100	length 985	WB 811/818



6. Perforated panel ARL

Perforated steel panel with 9 mm perforations at 38 mm centres. Panel hooks, page 17. Mount on accessory frame with screws.

Code	Dims mm	Suitable for
ARL 70	500 x 685	WB 815/818
ARL 100	500 x 985	WB 811/818

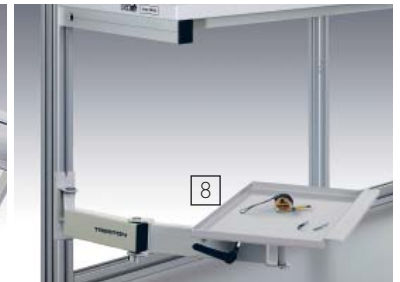

7. Support bracket HSB

Support bracket of steel for suspending power tools and lighting units. Mount on upright profiles.

Code	Length mm	Suitable for
HSB 110	1073	WB 811
HSB 150	1500	WB 815
HSB 180	1800	WB 818

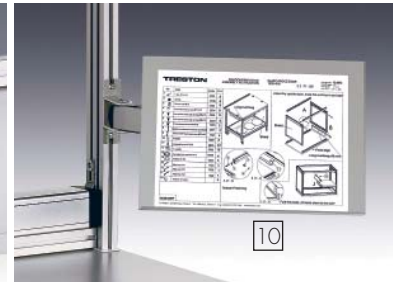

8. Swivel arm with tray AKV

Lockable, angle adjustable steel tray with swivel radius of 360°. Length of swivel arm 590 mm. Max. load 15 kg. Mount on upright profile.

Code	Tray mm	Suitable for
AKV 400	210 x 460	WB



9. Keyboard shelf WKA

Keyboard shelf with swivel arm. Epoxy powder coated steel. Load capacity 15 kg. Arm length 220 mm.

Code	Shelf mm	Suitable for
WKA	220 x 500	WB

10. Document stand WDA

Document stand A3 with swivel arm. Epoxy powder coated steel: light grey. Arm length 220 mm. Tilt 75°.

Code	Stand mm	Suitable for
WDA	440 x 300	WB



13. Cable channels

May be fitted with a choice of components, ordered separately. All meet with CE requirements. 3 m cable is included. Supplied wired and ready for use. A finished CJK 70 SET includes 3 double sockets (E1) and a switch (E2).

11. Cable tidy WBCT

Mount on frame. A cable tidy is standard equipment on motor and retractable handle bench

Code	Dims mm	Suitable for
WBCT 110*	64 x 204 x 948	WB 811
WBCT 150	64 x 204 x 1375	WB 815
WBCT 180	64 x 204 x 1675	WB 818

12. Cable clip set CC

The cable clip set will hold cables etc. securely and neatly in place along the bench frame. The clips locate in the 8 mm profile slot.

Code	Set	Suitable for
CC8	5 pieces	AL2X

Code	Dims mm	Suitable for
CJK 70	profile 631	WB 815/818
CJK 100	profile 931	WB 811/818
CJK 70 SET	3 double sockets (E1) and a switch (E2)	
COMPONENTS		
E1	Double socket	
E1 GB	Single socket	
E2 GB	Switched single socket	
E2	Switch	
E3	Automatic fuse 10 A	
E4	Automatic fuse/earth leakage switch 10 A/30 mA	
E5	Emergency-stop-switch	
E6	Data connector/shielded for Cat.6 cable	
E7	Data connector/without screen for Cat.5 cable	
E8	Pneumatic, quick coupling 3/8"	

*) Made to order

workstation WS

This flexible and versatile workstation can be adjusted for seated or standing operation. L-shaped for good leg room. Height adjustment of worktops by hydraulic electric motor, hydraulic retractable handle or allen-key between 700...1200 mm.

Workstation

The adjustment system is based on a rigid, sliding aluminium frame. Steel frame parts are epoxy powder coated light grey paint, RAL 7035. Worktops are of 25 mm laminated particle board, adjustable feet are provided for fine levelling. Load capacity 150 kg u.d.l. per workstation.

This unit consists of frame, worktop, shelf 310 x 900 mm, rear worktop 310 x 1060 mm with a rear lip, tool support and cable tidy. The rear worktop can be tilted between 0...20°

Code	Worktop mm	Model
WS 511	550 x 1060	Allen key
WS 515	550 x 1500	Allen key
WS 511 C	550 x 1060	Retractable handle
WS 515 C	550 x 1500	Retractable handle
WS 511 EL	550 x 1060	Electric motor
WS 515 EL	550 x 1500	Electric motor

1. Adjustable shelf WAS

Continuous adjustment for depth, height and angle. Shelf of 25 mm laminated particle board. Lipped front edge. Static load capacity 35 kg.

2. Bin profile BP

Aluminium profile for stacking and picking bins. Static load capacity 15 kg.

3. Extra shelf WFS

25 mm laminated particle board. Static load capacity 50 kg.

4. Rear worktop WBS

Tilted between 0...20°. Rear lip. 25 mm laminated particle board. Load capacity 80 kg.

5. Keyboard shelf WKA

Keyboard shelf with swivel arm. Epoxy powder coated steel. Arm length 220 mm. Load capacity 15 kg.

6. Document stand WDA

Document stand A3 with swivel arm. Epoxy powder coated steel: light grey. Arm length 220 mm. Tilt 75°.

7. Footrest

Footrest is adjustable for height and tilt. Mounted on WS frame. Footrest of polystyrene, connectors of steel.

8. Cable clip set CC

The cable clip set will hold cables etc. securely and neatly in place along the bench frame. The clips locate in the 10 mm profile slot.

9. Cable channels WJK

May be fitted with a choice of components, ordered separately. All meet with CE requirements. Cable channel is isolated from the workbench. 3 m cable is included.



ACCESSORIES

No.	Code	Dimensions D x L mm
1	WAS 90	400 x 870
2	BP 90	length 895
3	WFS 90	310 x 900
4	WBS 311	310 x 1060
5	WKA	shelf 220 x 550
6	WDA	stand 440 x 300
7	WJT	500 x 370
8	CC10	5 pcs/set
9	WJK 90	profile 840

COMPONENTS

E1	Double socket
E1 GB	Single socket
E2 GB	Switched single socket
E2	Switch
E3	Automatic fuse 10 A
E4	Autom./earth leakage switch 10 A/30 mA
E5	Emergency-stop-switch
E6	Data connector/shielded for Cat.6
E7	Data connector/without screen for Cat.5
E8	Pneumatic, quick coupling 3/8"

workbenches TP



These ergonomic workbenches are suitable for light assembly. The modular construction allows many possibilities when planning a layout

1. Workbench TP

Height adjustment with allen-key between 650...900 mm. Frames are of epoxy powder coated steel in grey RAL 7045. The worktops are of 25 mm laminated particle board.

2. Line extension TP - L

Each standard TP-workbench may also be supplied as a line extension. Stock sizes are shown.

3. Angle extension TP -K

Each standard TP-workbench may also be supplied as a angle extension. Stock sizes are shown.

4. Corner workbench TP KK

A corner workbench can be used with two TP-K benches to create a 90 deg. angle setup. This unit consists of a worktop, two side frames and a leg in the middle. Load capacity 150 kg u.d.l.

>>>

No.	Code	Worktop mm	Load capacity static u.d.l.
1	TP 507	500 x 700	150 kg
	TP 510	500 x 1000	150 kg
	TP 515	500 x 1500	150 kg
	TP 710	700 x 1000	300 kg
	TP 712	700 x 1200	300 kg
	TP 715	700 x 1500	300 kg
	TP 718	700 x 1800	300 kg
	TP 915	900 x 1500	300 kg
	TP 918	900 x 1800	300 kg
	2	TP 710L	700 x 1000
TP 712L		700 x 1200	150 kg
TP 715L		700 x 1500	150 kg
TP 718L		700 x 1800	150 kg
TP 915L		900 x 1500	150 kg
TP 918L		900 x 1800	150 kg
3		TP 510K	500 x 1000
	TP 712K	700 x 1200	150 kg
4	TP 707 KK	1100 x 1100	150 kg
	TP 909 KK	1300 x 1300	150 kg

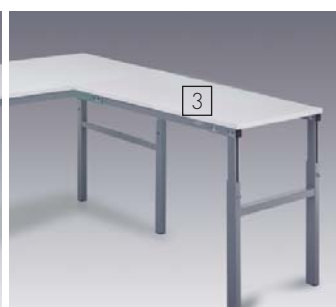
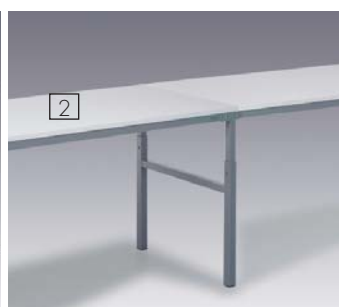

workbenches TPH/SAP



1. Workbench TPH

Height adjustment with allen-key between 650...900 mm. Workbench with upright profiles and a laminate shelf, depth 310 mm, height adjustment between 1080...1550 mm, load capacity 50 kg. Frames are of epoxy powder coated steel in grey RAL 7045. The worktops are of 25 mm laminated particle board. There are a large range of workbench accessories available.

2. Corner workbench TPH KK

A corner workbench can be used with two TPH benches to create a 90 deg. angle setup. This unit consists of a worktop and all necessary components. Load capacity 150 kg u.d.l.

3. Moveable bench SAP

Construction as TP. Height adjustment with allen key between 650..900 mm. Swivel castors Ø 100 mm of which two are braked. Load capacity 150 kg. Lower shelf available separately.

4. Lower shelf AT

For moveable bench.

No.	Code	Worktop mm	Load capacity static u.d.l.
1	TPH 712	700 x 1200	300 kg
	TPH 715	700 x 1500	300 kg
	TPH 718	700 x 1800	300 kg
	TPH 915	900 x 1500	300 kg
	TPH 918	900 x 1800	300 kg
	2	TPH 707 KK	1100 x 1100
TPH 909 KK		1300 x 1300	150 kg
3	SAP 507	500 x 700	150 kg
	SAP 710	700 x 1000	150 kg
	SAP 715	700 x 1500	150 kg
4	AT 507	500 x 700	40 kg
	AT 710	700 x 1000	40 kg

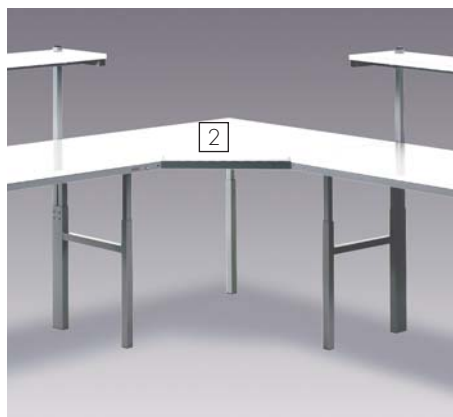

Accessories are mounted between vertical C-profiles, Steel parts are epoxy powder coated in light grey RAL 7035. The shelves are 25 mm laminated particle board

1. Metal shelf TH

Adjustment for depth, height and angle. For stacking and picking bins. Load capacity 30 kg.

2. Bin profile BP

Aluminium profile for stacking and picking bins.

3. Auxiliary shelf SH

Height adjustable shelf. 25 mm laminate.

4. Perforated panel RL

Robust, perforated steel panel. 9 mm perforations at 38 mm centres. Mount on TPH-benches with connectors RK 1. Can also be attached to a wall with screws (included). Panel hooks, page 17.

5. Tool and lighting support KT

For suspending power tools and lighting units. Includes one C-profile bar with sliding hook.

6. Cable tidy TPHCT

Mounted between C-profiles below worktop. Of perforated epoxy powder coated steel.

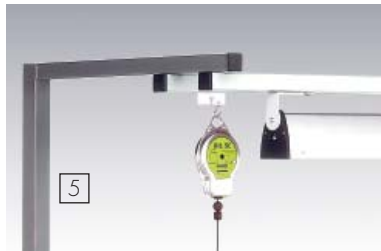
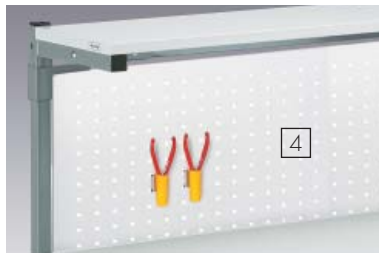
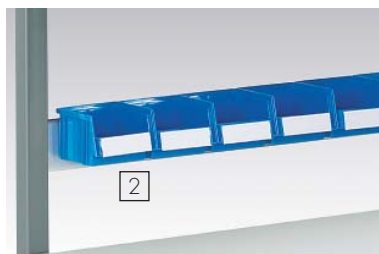
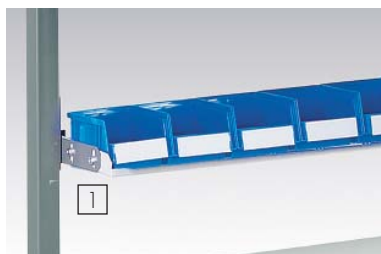

No.	Code	Dims D x W x H mm	Load	Suitable for
1	TH 120	145 x 1119	30 kg	TPH 712
	TH 150	145 x 1419	30 kg	TPH 715/915
	TH 180	145 x 1719	30 kg	TPH 718/918
2	BP 120	profile 1115	15 kg	TPH 712
	BP 150	profile 1415	15 kg	TPH 715/915
	BP 180	profile 1715	15 kg	TPH 718/918
3	SH 150	310 x 1500	50 kg	TPH 715/915
	SH 180	310 x 1800	50 kg	TPH 718/918
4	RL 120	700 x 1200	300 kg	TPH 712
	RL 150	700 x 1500	300 kg	TPH 715/915
	RL 180	700 x 1800	300 kg	TPH 718/918
	RK 1	connectors (4 pcs)		TPH
5	KT 120	600 x 1200		TPH 712
	KT 150	600 x 1500		TPH 715/915
	KT 180	600 x 1800		TPH 718/918
	Extra C-profile			
	SPR 150	1500		KT 150
	SPR 180	1800		KT 180
6	TPHCT 120	45 x 205 x 1115		TPH 712
	TPHCT 150	45 x 205 x 1415		TPH 715/915
	TPHCT 180	45 x 205 x 1715		TPH 718/918
7	CKV 400	tray 210 x 460	50 kg	TPH
8	CC 12	5 pcs/set		TPH
9	TJK 120	profile 1058		TPH 712
	TJK 150	profile 1358		TPH 715/915
	TJK 180	profile 1658		TPH 718/918
	TJK 150 SET	includes 3 x E1, 1 x E2		TPH 715/915
	TJK 180 SET	includes 3 x E1, 1 x E2		TPH 718/918
	COMPONENTS			
	E1	Double socket		
	E1 GB	Single socket		
	E2 GB	Switched single socket		
	E2	Switch		
	E3	Automatic fuse 10 A		
	E4	Autom./earth leakage switch 10 A/30 mA		
	E5	Emergency-stop-switch		
	E6	Data connector/shielded for Cat.6		
	E7	Data connector/without screen for Cat.5		
	E8	Pneumatic, quick coupling 3/8"		

7. Swivel arm with tray CKV

Swivel arm with lockable, angle adjustable steel tray. Load 15 kg. Mount on C-profile.

8. Cable clip set CC

The clips locate in the 12 mm profile slot..

9. Cable channel

May be fitted with a choice of components, ordered separately. 3 m cable is included.

The finished TJK 150 SET and TJK 180 SET include 3 double sockets (E1) and a switch (E2).



heavy duty workbenches HDB/HDBL

Heavy duty workbenches for production and assembly areas, service centres and workshops. Benefits: robust construction, modern design and versatile accessories.

Three top choices

- S= zinc plated steel on particle board. Worktop thickness 42 mm. Load capacity 750 kg.
- P= PVC laminated particle board. Thickness 40 mm. Load capacity 500 kg.
- W= birch plywood. Thickness 40 mm. Load 750 kg.



Heavy duty workbench HDB

This unit consists of worktop, bracing panel and 2 leg frames. Worktop height is 845 mm. Frames are of epoxy powder coated steel in grey RAL 7045. Bracing member for additional stability and lipped back edge; also acts as attachment point for vertical posts.

Code	Dims mm	Worktop	Load capacity
HDB 715S	750 x 1500	steel	750 kg
HDB 715P		PVC	500 kg
HDB 715W		birch	750 kg
HDB 718S	750 x 1800	steel	750 kg
HDB 718P		PVC	500 kg
HDB 718W		birch	750 kg



Heavy duty workbench HDBL

This unit consists of worktop, bracing panel and 1 leg frame. Worktop height is 845 mm. The other leg frame will be replaced with a steel cabinet ML 06 which is ordered separately, see page 14. Cover MLS is needed for mounting metal cabinets to benches.

Code	Code	Dims mm	Worktop	load capacity
HDBL 715S-R	HDBL 715S-L	750 x 1500	steel	750 kg
HDBL 715P-R	HDBL 715P-L		PVC	500 kg
HDBL 715W-R	HDBL 715W-L		birch	750 kg
HDBL 718S-R	HDBL 718S-L	750 x 1800	steel	750 kg
HDBL 718P-R	HDBL 718P-L		PVC	500 kg
HDBL 718W-R	HDBL 718W-L		birch	750 kg

ML 06
Cabinet to right side

ML 06
Cabinet to left side

NOTE! Cabinet and cover available separately.

1. Frame HF

Needed for mounting accessories to benches. Mount on bracing panel. Includes 3 vertical aluminium profiles and 1 horizontal steel profile.

2. Steel shelf HSS

Adjustment for depth, height and angle. With retaining lip, rear or front mounting.

3. Bin profile BP

Height adjustable aluminium bin rail, to hold Treston stacking and picking bin

4. Perforated panel HPP

Steel panel. 9 mm perforations at 38 mm centres. Mount on accessory frame with screws. Panel hooks, page 17.

5. Cupboard unit HCU

Constructed of perforated steel: 9 mm perforations at 38 mm centres. Lock, steel shelf and connectors as standard. Dimensions 310 x 687 x 700 mm.

6. Support bracket HSB

For suspending power tools and lighting units. Includes one bar with sliding hook and second bar for lighting units.

7. Lower shelf HLS

Steel lower shelf in two parts. Can be used as one part shelf too. Load capacity 100 kg static u.d.l.

8. Height adjustment kit HAK

Allows height adjustment to be made in 25 mm increments between 845 - 1095 mm.

9. Cable channel CJK

May be fitted with a choice of components, ordered separately. All meet with CE requirements. 3 m cable is included. Supplied wired and ready for use. A finished CJK 70 SET includes 3 double sockets (E1) and a switch (E2).



No	Code	Dims D x W x H mm	Load	Suitable for
1	HF 150	692 + 692		HDB/HDBL 715
	HF 180	692 + 992		HDB/HDBL 718
2	HSS 73	310 x 686	15 kg	HDB/HDBL 715 HDB/HDBL 718
	HSS 103	310 x 986	15 kg	HDB/HDBL 718
3	BP 70	profile 685	15 kg	HDB/HDBL 715 HDB/HDBL 718
	BP 100	profile 985	15 kg	HDB/HDBL 718
4	HPP 73	686 x 750		HDB/HDBL 715 HDB/HDBL 718
	HPP 103	986 x 750		HDB/HDBL 718
5	HCU73	310 x 687 x 700		HDB/HDBL 715 HDB/HDBL 718
6	HSB 150	1500		HDB/HDBL 715
	HSB 180	1800		HDB/HDBL 718
7	HLS 515	500 x 1500	100 kg	HDB 715
	HLS 518	500 x 1800	100 kg	HDB 718
8	HAK	4 pcs/set		HDB
9	CJK 70	profile 631		HDB/HDBL 715 HDB/HDBL 718
	CJK 100	profile 931		HDB/HDBL 718
	CJK 70 SET	includes 3 x E1, 1 x E2		HDB/HDBL 715 HDB/HDBL 718
COMPONENTS				
E1	Double socket			
E1 GB	Single socket			
E2 GB	Switched single socket			
E2	Switch			
E3	Automatic fuse 10 A			
E4	Automatic fuse/earth leakage switch 10 A/30 mA			
E5	Emergency stop-switch			
E6	Data connector/shielded for Cat.6 cable			
E7	Data connector/without screen for Cat.5 cable			
E8	Pneumatic, quick coupling 3/8"			

metal cabinets ML



Cabinet ML 04 includes fluted rubber mat on top, handle and 4 castors Ø 100 mm, 2 with brakes

Drawer	
Outer height mm	inner height mm
60	50
120	110
140	130
180	170
360	350



Centrally locked high quality steel cabinets for storage of tools and small components. Mounted under workbenches with brackets (included). One model available with wheels as an independent tool trolley. Six size alternatives. Steel cabinets are epoxy powder coated in grey paint, RAL 7045. Central locking. Full width drawer handle in anodised aluminium. Smooth and quiet telescopic ball-race runners and clear opening of 405 mm. Load capacity 35 kg/drawer. Drawer size 500 x 406 mm.

Suitability

- For TP/TPH/SAP benches of 700 mm depth and over, all cabinets are suitable. Mounting brackets for these benches are included.
- For HDB/HDBL benches all cabinets are suitable. Cover MLS needed for mounting, ordered separately.
- For WB benches we recommend cabinets ML 01 and ML 02. Cover MLS needed for mounting, ordered separately.

Dividers MLX 1

Includes 7 fixed compartments. Height 50 mm.

Dividers MLX 2/50

Includes a frame, 3 longitudinal dividers and 15 internal dividers. Height 38 mm. Galvanised steel.

Dividers MLX 2/100

Includes a frame, 3 longitudinal dividers and 15 internal dividers. Height 68 mm. Galvanised steel.

Cover MLS







Needed for mounting cabinets to WB/HDB/HDBL benches.



MLX1



MLX2/50

	Code	Includes drawers Outer height mm	Outer dims D x L x H mm
	ML 01	1 x 140	580 x 453 x 142
	ML 02	1 x 60 2 x 120	580 x 490 x 351
	ML 03	1 x 60 2 x 120 1 x 180	580 x 490 x 532
	ML 04	1 x 60 2 x 120 1 x 180 + top, handle and 4 castors	580 x 490 x 670
	ML 05	1 x 120 1 x 360	580 x 490 x 532
	ML 06	1 x 60 2 x 120 2 x 180 + plinth, H = 110 mm	580 x 490 x 762





light steel cabinets LMC



These modern steel cabinets are an ideal way of providing individual secure storage for your staff. Four new cabinet sizes, including one drawer/cupboard combination. These cabinets suit any Treston workbench. The cabinet frames are epoxy powder coated steel; drawer fronts are composite board with aluminium handles. Colour light grey, RAL 7035. Drawers open to 75% of drawer depth; load capacity is 20 kg per drawer. Mount on benches with brackets (included).

- Suitable for
- WS/WB/TP/TPH workbenches
 - SAP/CTR/WTR trolleys

Cover LMCK2
 Needed for mounting cabinets to WB benches.

	Code	Includes drawers Outer height mm	Outer dims D x L x H mm
	LMC 01	1 x 100	460 x 370 x 140
	LMC 02	2 x 100	460 x 370 x 345
	LMC04	4 x 100	460 x 370 x 455
	LMC04D	1 x 100 + cupboard, height 300 mm, open to right	460 x 370 x 455

In the picture:
 Bench WB 815
 Cabinet LMC 02
 Cover LMCK2



In the picture:
 Trolley SAP 710
 Steel cabinet LMC 02
 Lower shelf AT 710



computer accessories

These accessories are practical and space saving.

Keyboard shelf NT 500 ESD

A pull-out keyboard shelf with integral wrist support and mouse pad to mount underneath the bench worktop.

Outer dims D x L x H 250 x 500 x 110 mm.

Suitable for

- WB/WS/TP/TPH- workbenches
- SAP/CTR/WTR- trolleys



PC stand CPU

An adjustable holder for either vertical or horizontal CPU, to mount underneath the bench worktop. Suitable for WB/WS/TP/TPH benches and SAP/CTR/WTR trolleys.

Width	Height
130...240 mm	395...500 mm/
340...460 mm	180...285 mm

Suitable for

- WB/WS/TP/TPH- workbenches
- SAP/CTR/WTR- trolleys



LCD bracket MH

A flat panel monitor bracket/plate to suit monitors with mounting holes at 75/100mm centres.

Suitable for

- WS/WB benches
- TPH benches, connector MHHKC needed for mounting, ordered separately.
- WTR trolley



LCD swivel arm MA

A flat panel monitor arm and plate to suit monitors with mounting holes at 75/100 mm centres. The arm is double articulated, turns through a radius of 180° and will extend between 95-425 mm from the upright.

Suitable for

- WS/WB benches
- TPH benches, connector MHHKC needed for mounting, ordered separately.
- WTR trolley

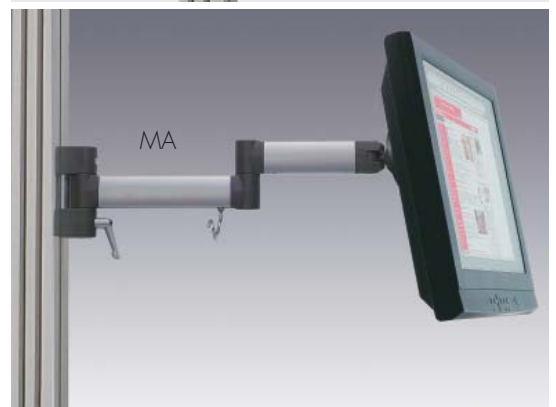

Bottle holder CH

Practical holder for bottle or cup. Made of black polypropylene. Inside diameter 80 mm. Outside dimensions: L x W x H: 110 x 105 x 120 mm

Suitable for :

- AL2X-, WS-, WTR profile



perforated panels, hooks

Perforated panels ARL/HPP/RL

Perforated panels with 9 mm perforations at 38 mm centres. Epoxy powder coated steel in light grey RAL 7035. Three different panel types available.

Panel	Dims mm	Suitable for
ARL 70	500 x 670	WB 815/818
ARL 100	500 x 970	WB 811/818
HPP 73	686 x 750	HDB/HDBL 715/718/IT 170
HPP 103	986 x 750	HDB/HDBL 718/HAT 610
RL 120	750 x 1119	TPH 712/wall mounting
RL 150	750 x 1419	TPH 715/915/wall mounting
RL 180	750 x 1719	TPH 718/918/wall mounting
RK 1	Connector	Needed for mounting panels on TPH-benches



Product	Code	Dimensions
1. Base plate	K 001	
2. Universal hook	K 010	24 mm
	K 011	38 mm
	K 012	100 mm
	K 013	150 mm
3. Right-angle hook	K 020	10 mm
	K 021	50 mm
4. Slanted hook	K 030	50 mm
	K 031	100 mm
5. Double hook	K 040	25 x 55 mm
	K 041	25 x 100 mm
	K 042	25 x 150 mm
6. Circle hook	K 050	∅ 60 mm
7. Package hook	K 060	170 mm
8. Pliers hook	K 070	20 x 43 mm
9. Power tool hook	K 080	∅ 60 mm
	K 081	∅ 80 mm
10. Spring clip	K 090	∅ 12 mm
	K 091	∅ 18 mm
	K 092	∅ 25 mm
11. Tubular cup	K 101	26 x 75 mm
12. Bin rail	K 110	100 mm
13. Round cup	K 120	30 x 82 mm
14. Drill shelf	K 130	42 x 238 x 40 mm
15. Chisel shelf	K 131	220 x 22 x 32 mm
16. Steel shelf	K 133	120 x 350 mm
17. Hose shelf	K 134	160 x 125 mm

Cupboard unit HCU 73

Constructed of perforated steel: 9 mm perforations at 38 mm centres. Lock, steel shelf and connectors as standard. Outer dimension D x W x H: 310 x 687 x 700 mm.

Panel hooks

Our range of panel hooks fits TRESTON perforated panels as well as many other common panel types. All hooks are zinc-plated steel with locking screws.

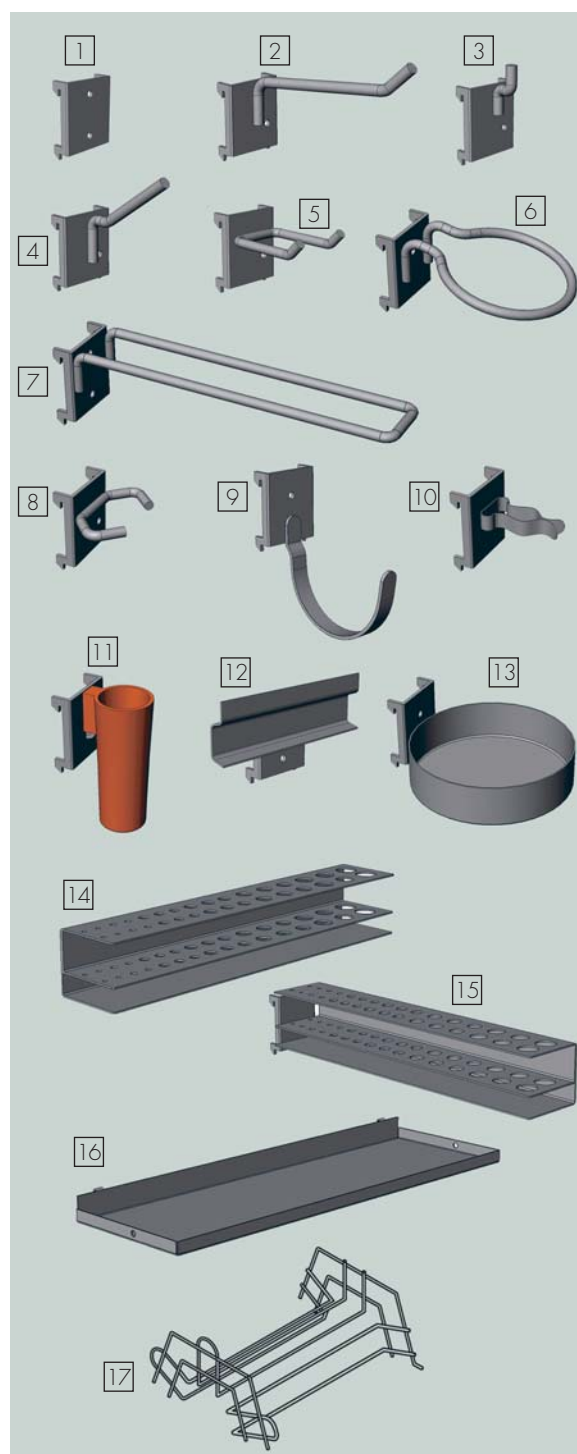

energy panels

Constructed from aluminium profile, this range of compact energy panels provides power distribution for our benches and workstations. Simple to assemble, it may be fitted with a choice of components, ordered separately. Cable channel is isolated from the workbench. 3 m cable is included. Aluminium profile 72 x 72 mm

Energy panel CJK/WJK/TJK/PJK

All meet with CE requirements. Cable channel is isolated from the workbench. May be fitted with a choice of components, ordered separately. All meet with CE requirements. 3 m cable is included.

Panel	Profile length	Suitable for
CJK 70	631 mm	WB 815/818/ HDB 715/718
CJK 100	931 mm	WB 811/818/ HDB/HDBL 718
WJK 90	840 mm	WS 511/515
WJK 40	470 mm	WTR 140
TJK 120	1058 mm	TPH 712
TJK 150	1358 mm	TPH 715/915
TJK 180	1658 mm	TPH 718/918
PJK 70	640 mm	P 0712/0720
PJK 100	640 mm	P 1012/1020

Panel Sets include

3 double sockets (E1) and a switch (E2).

CJK 70 SET	WB 815/818/ HDB 715/718
TJK 150 SET	TPH 715/915
TJK 180 SET	TPH 718/918

COMPONENTS

E1	Double socket (max. 5 pcs/1 cable)
E1 GB	Single socket
E2 GB	Switched single socket
E2	Switch
E3	Automatic fuse 10 A
E4	Automatic fuse/ earth leakage switch 10 A/30 mA
E5	Emergency-stop-switch
E6	Data connector/shielded for Cat.6 cable
E7	Data connector/without screen for Cat.5
E8	Pneumatic, quick coupling 3/8"

Outlet panel PRK 5

Outlet panel has 5 Schuco wall sockets, switch and 3 m cable. Mount on upright profile of TRESTON-benches WB/WS/TP/TPH and trolley CTR/SAP/WTR with connectors (included). Can also be attached under the laminate shelf with screws.



lighting units



Lighting is an essential part of workstation ergonomics, as well designed lighting aids industrial safety, comfort and productivity. Treston lighting units are specifically designed to fulfil this function. Particular applications need both sidelights and overhead. This system provides the best possible illumination. Quick, flicker-free electronic light ignition and vibration-less operation. Light output unaffected by fluctuations in voltage. Suitable for use with moving machinery giving asymmetric lighting with minimal shadow. (Flicker free tubes ensure that rotating objects will not appear to be stationary, a common optical effect when standard fluorescent tubes are used.)

Overlight OL 254

Silver grey anodized aluminium frame with a matte anti-dazzle screen. Angle continuously adjustable. Quick, flicker-free electronic light ignition. With own switch and 3 m cable. The lighting units are isolated from the workbench. Mount on support bracket for WB/WS/TPH/HDB/HDBL-benches with fittings supplied.

Length: 1200 mm.
Enclosure class: IP 20.
2 x fluorescent tubes: 54W

Overlight with dimmer OL 254 D

A dimmer and 3 m cable are included.

Length: 1200 mm.
Enclosure class: IP 20.
2 x fluorescent tubes: 54W

Sidelight SL 224

Construction as OL 254. Mount on vertical aluminium profile of WS/WB/HDB/HDBL benches with fittings supplied. Connectors and screws as standard.

Length: 590 mm
Enclosure class: IP 20
2 x fluorescent tubes: 24W

Accessories: Mounting kit SL-HKC required for use with TPH benches; ordered separately.



Graph of light intensity

Light intensity (lux) is tested on a horizontal worktop using the OL 254. The diagram right shows the results. Worktop size is 700 x 1500 mm, height of light unit above worktop is 1000 mm.

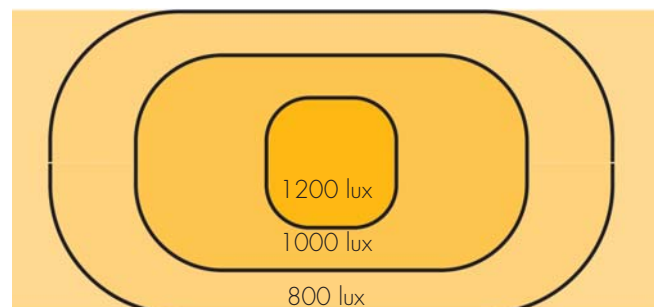

universal trolley WTR

A good quality, versatile trolley, PC-station, measuring station or mobile storage. Modern industrial design.

1. Universal trolley WTR 140

Standard trolley has 3 shelves (TS 605), size 650 x 530 mm. Height adjustment of shelves by allen-key. The vertical profiles are of aluminium. Frames are of epoxy powder coated steel: light grey RAL 7035. The worktops are of 25 mm laminated particle board. Four swivel castors Ø 125 mm of which two are braked, overall height of castor 141 mm. Load capacity 150 kg. Outer dimensions D x W x H: 650 x 650 x 1415 mm.

2. Extra shelf TS 605

Shelf of 25 mm laminated particle board, size 650 x 530 mm. Load capacity 50 kg.

3. Adjustable shelf TAS 605

Continuous adjustment for depth, height and angle. 25 mm laminated particle board, size 650 x 530 mm. Lipped front edge. Load capacity 50 kg.

4. Bin profile BP 50

Aluminium profile for TRESTON stacking and picking bins. Length 525 mm.

5. Cable channel WJK 40

May be fitted with a choice of components, ordered separately. All meet with CE requirements. 3 m cable is included. Profile length 470 mm.

COMPONENTS

- E1 Double socket (max. 5 pcs/1 cable)
- E1 GB Single socket
- E2 GB Switched single socket
- E2 Switch
- E3 Automatic fuse 10 A
- E4 Automatic fuse/earth leakage switch 10 A/30 mA
- E5 Emergency-stopswitch
- E6 Data connector/shielded for Cat.6 cable
- E7 Data connector/without screen for Cat.5
- E8 Pneumatic, quick coupling 3/8"

Light steel cabinets, page 15

Keyboard shelf, page 16



adjustable trolleys TRTA

For general use in workshop, office, production areas, hospitals. Height of all shelves can be adjusted by allen-key. Standard trolley has 2 or 4 shelves. More shelves can be mounted on either version.

Adjustable trolleys TRTA

Frames are of epoxy powder coated steel in grey (RAL 7045). Shelves 12 mm laminated particle board with steel edging. Four swivel castors Ø 125 mm, two with brakes, overall height of castor 161 mm.

2-shelf trolleys

Shelf adjustments between 200...770 mm. Load capacities: max.150 kg/trolley and max. 50 kg/shelf.

4-shelf trolleys

Shelf adjustments between 215...1340 mm. Load capacities: max.300 kg/trolley and max. 50 kg/shelf.



1. Extra shelf TRHA

Suitable for all trolleys. Load capacity 50 kg.

2. End mesh panels NET 2

Steel mesh epoxy coated in grey (RAL 7045). Screws included. Size 364 x 604 mm.

3. Document holder DSA4 ESD

Holder for A4 documents, includes two magnets.

Each shelf is height adjustable to individual requirements, shelf height easily set using index marks on the trolley frame.

TROLLEY	EXTRA SHELF		
2-shelf trolley	Shelf size D x W mm	Outer measurements D x W x H mm	
TRTA 4082	430 x 800	535 x 900 x 1015	TRHA 408
TRTA 4102	430 x 1000	535 x 1100 x 1015	TRHA 410
TRTA 5082	530 x 800	635 x 900 x 1015	TRHA 508
TRTA 5102	530 x 1000	635 x 1100 x 1015	TRHA 510
4-shelf trolley			
TRTA 4104	430 x 1000	535 x 1100 x 1535	TRHA 410
TRTA 5104	530 x 1000	635 x 1100 x 1535	TRHA 510



industrial trolley IT

A versatile trolley that has been designed for use in light assembly, test and repair areas.

1. Industrial trolley IT 170

Frames are of epoxy powder coated steel in grey RAL 7045, with perforated profiles. One perforated panel is included with the trolley, size 200 x 685 mm. Bottom shelf of steel with fluted rubber mat. Four castors Ø 125 mm, two with brakes. Load capacity 150 kg. Overall dimensions D x W x H: 625 x 777 x 1725 mm.

2. Steel shelf ISS

Adjustment for height, depth and angle 0...30°. With front retaining lip. Load capacity 40 kg. Two sizes.

Code	Dimensions
ISS 407	400 x 680 mm
ISS 607	600 x 680 mm

3. Perforated panel HPP 73

Perforated panel of epoxy powder coated steel in light grey. 9 mm perforations at 38 mm centres. Size 686 x 750 mm.

4. Bin rail BP 70

Height adjustable aluminium bin rail, to hold Treston stacking and picking bins. Length 685 mm.

5. Cupboard unit HCU 73

Constructed of epoxy powder coated, perforated steel in light grey: 9 mm perforations at 38 mm centres. Lock, steel shelf and connectors as standard. Dimensions D x W x H: 310 x 687 x 700 mm.



Combination in the picture:
1 x trolley IT 170
2 x shelf ISS 407
1 x shelf ISS 607

Combination in the picture:
1 x trolley IT 170
1 x perforated panel HPP 73
1 x bin profile BP 70

Combination in the picture:
1 x trolley IT 170
1 x shelf ISS 607
1 x cupboard unit HCU 73

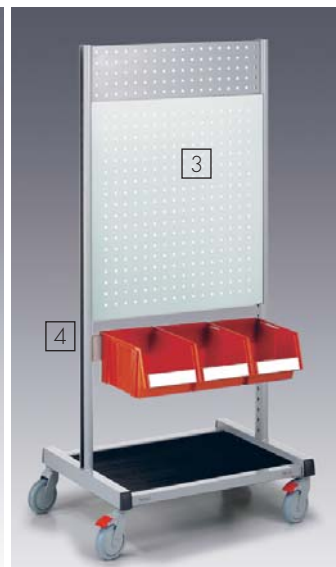
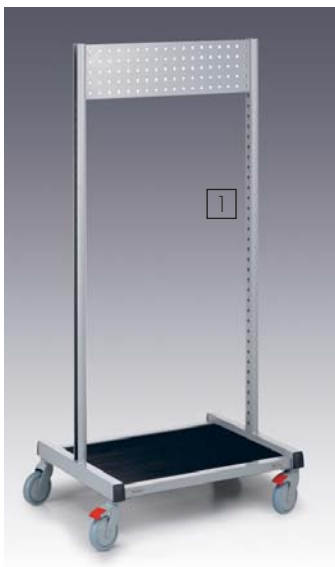

assembly trolleys HAT/RV

1. Assembly trolley HAT 610

Frames are of epoxy powder coated steel in grey RAL 7045. Worktop of zinc plated steel on particle board, 42 mm. A lower shelf is integrated, of steel. Four castors Ø 125 mm, two with brakes. Load capacity 400 kg. Overall dimensions D x W x H: 600 x 1073 x 850 mm.

2. Frame HF 100

Dimension 992 mm.

3. Bin rail BP 100

Height adjustable aluminium bin rail, to hold Treston stacking and picking bins. Load capacity 15 kg. Length 985 mm.

4. Steel shelf HSS 103

Adjustment for depth, height and angle. With retaining lip, rear or front mounting. Load capacity 15 kg. Dimensions 310 x 986 mm.

5. Perforated panel HPP 103

Steel panel. 9 mm perforations at 38 mm centres. Mount on aluminium profiles with screws. Dimensions 986 x 750 mm.

6. Cupboard unit HCU 73

Constructed of perforated steel: 9 mm perforations at 38 mm centres. Lock, steel shelf and connectors as standard. Dimensions D x W x H: 310 x 687 x 700 mm. Mount on HAT-trolley with connectors HCU-HAT, available separately.



7. Heavy duty trolley RV 608

Frames are of epoxy powder coated steel in two tone grey: light grey RAL 7035 and grey RAL 7045. Worktop of steel with fluted rubber mat. Four castors Ø 125 mm, two with brakes. Handle. Load capacity 300 kg. Dimensions D x W x H: 600 x 767 x 845 mm

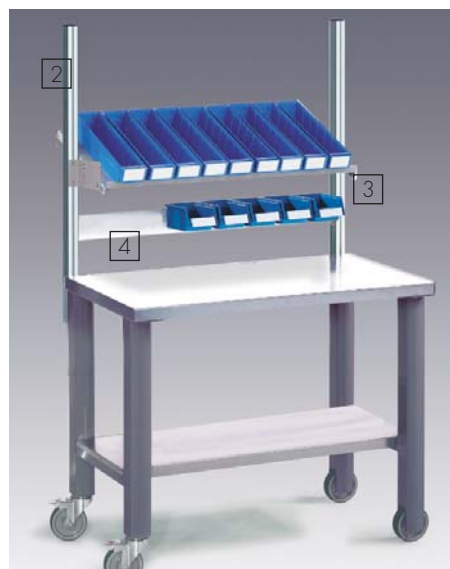
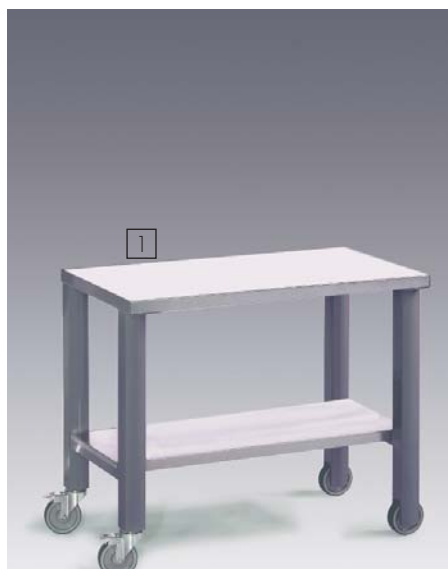

chairs TTJ/KJ

Using Treston chairs and footrests you will be sitting correctly and comfortably. A well designed chair aids posture and helps prevent fatigue and back pain.

Upholstered chairs

Ergonomically designed chair with gas lift height adjustment, adjustable backrest, and blue upholstery. The base has five twin 50 mm dia. swivel castors, which are automatically braked when not loaded.

Chair TTJ 3

Seat height: 430... 570 mm
 Seat: 440 x 440 mm
 Back rest: 390 x 260 mm

Chair TTJ 4

The seat has an adjustable tilt to provide better support and flexibility.

Seat height: 430...570 mm
 Seat: 440 x 440 mm
 Back rest: 390 x 260 mm

High chair TTJ 5

With a foot rest that follows the seat height. Non-marking floor glides.

Seat height: 500...750 mm
 Seat: 440 x 440 mm
 Back rest: 390 x 260 mm

Saddle stool KJ 200

Saddle seat. Tilt of seat adjustable.
 Seat height: 540... 800 mm.
 Foot rest to order.



Industrial chairs

Seat and back rest of preformed black polyurethane. Gas lift controlled height adjustment. Adjustable back rest. Swivelling castors Ø 50 mm, braked when unloaded.

Chair TTJ 1 PU

Seat height: 430... 570 mm
 Seat: 400 x 370 mm
 Back rest: 370 x 230 mm

High chair TTJ 2 PU

With non-marking floor glides. Foot rest which follows the seat height

Seat height: 500...750 mm
 Seat: 400 x 370 mm
 Back rest: 370 x 230 mm

Stool TJ 1 PU

Seat height: 430... 570 mm

Fitters stool TJAS

Seat of black integral rubber. Grey rubber castors, 2 with brakes. With a red tool tray and 2 removable accessory boxes. Seat height: 310... 385 mm

Arm rests KN 1

Arm rest can be easily adjusted for width.
 Suitable for : TTJ 3, TTJ 4, TTJ 5. TTJ 1 PU and TTJ 2 PU.



packing station PPH

Well-presented packages and parcels give an important first impression for any company. TRESTON packing stations ensure that valuable and vulnerable products are packed on equipment specifically designed for the task.

1. Packing bench PPH

Height adjustment of worktops 760...1050 mm. The worktop overhangs the frame by 300 mm and this can be set to the left or right side during assembly. Bench with upright profiles and a laminate shelf, height adjustment between 1100... 1650 mm: the upper shelf has 6 steel divider hoops for holding cartons. Supports for paper and cardboard rolls. Frame construction of the packing bench is the same as TP/ TPH-workbenches, so TPH accessories can be used.

Code	Worktop mm	Frame mm
PPH 918	900 x 1800	900 x 1500
PPH 921	900 x 2100	900 x 1800



2. Cutter PPL 170

Cuts paper, corrugated cardboard and most other packaging materials - not suitable for bubble wrap. Frame is of epoxy powder coated steel in light grey RAL 7035. Total length 1700 mm. Cutting length 1500 mm.

3. Equipment bin PPH TL

For tape roll and scissors etc. A red stacking bin 1950-5 with an underbench supporting frame for packing equipment. Dimensions of bin 500 x 186 x 182 mm.



Foot rest JT 2

The feature of this foot rest is the fluted exercise roller which revitalises the feet while working. The surface is corrugated to prevent slipping. Colour grey. Material polystyrene. Dimensions: 500 x 370 x 100 mm.



industrial office- screen system

The compact and modern Treston Industrial Office Screen system with panel and accessory options can be used almost anywhere in a company; from production facilities to offices. Screens are made of antistatic materials. Create a uniform, stylish outlook with the Treston screens throughout your company!

Screen panels

An anodized aluminium frame holds panels made of blue or grey fabric panelling or perforated panel. The fabrics are antistatic. The perforated steel panel is epoxy powder coated in light grey RAL 7035, 9 mm perforations at 38 mm centres. Divider screen panels can be used individually, in straight lines, or at right angles to form enclosed spaces. There are four different panel sizes.

Legs

- TLEG 400 is suitable for all low panels, and high fabric panels. Complete assembly's height: 1275 -1315 mm (low panels) 2030 -2070 mm (high panels)
- TLEG 600 is suitable for all high panels, fabric and steel. Adjustable feet are provided for fine levelling. Complete assembly's height: 2070 - 2080 mm.
- CLEG- corner leg set for all panels. Can be used with two panels to create a 90 deg corner.
- LLEG 250 is suitable for all low panels, and high fabric panels. Complete assembly's height: 1275 -1315 mm (low panels) 2030 -2070 mm (high panels)
- One screen panel will need a panel and two legs, which are ordered separately.
- Straight line assemblies require two legs for the first panel and one leg for each additional panel.





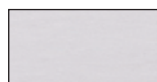

FB
Colour: blue, RAL 5010
Acoustic panel: polyether/wood. Thickness: 32 mm .

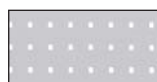

FG
Colour: grey RAL 7035
Acoustic panel: polyether/wood. Thickness: 32 mm



S
Colour: grey RAL 7035
Perforated screen: steel . Thickness: 1,5 mm

Screen panels				Suitability of legs (ordered separately, 1 pcs per pack)			
			Outer dims L x H mm				
Blue fabric	Grey fabrics	Perf. panel		Tleg 400	Tleg 600	Lleg 250	Corner leg set
P 0712 FB	P 0712 FG	P 0712 S	750 x 1245	TLEG400	—	LLEG250	CLEG
P 0720 FB	P 0720 FG	P 0720 S	750 x 2000	TLEG400*	TLEG600	LLEG250*	CLEG
P 1012 FB	P 1012 FG	P 1012 S	1050 x 1245	TLEG400	—	LLEG250	CLEG
P 1020 FB	P 1020 FG	P 1020 S	1050 x 2000	TLEG400*	TLEG600	LLEG250*	CLEG

*) We recommend this leg for the low panels but it can be mounted to high fabric panels and all corner layouts.

Noise from production areas or loud talking from neighboring workstations are often disturbing factors. One way of reducing the noise level is to divide workspaces from each other and/or separate them from production areas. This can be easily done with Treston screens. An individual workstation aids concentration and improves accuracy. With Treston screens noise levels can be reduced on average, by 7-9 dB to the standard ISO 10053. (VTT Research centre Finland).



Bin rail PBP

Aluminium rail for TRESTON stacking bins 1015, 1520, 1525 and 1930. Load capacity 10 kg. Aluminium profile/semiconductive epoxy powder coated steel. Max 3 profiles/one side.

Steel shelf PSS

Steel semiconductive epoxy powder coated shelf. The shelf can sit on the brackets as normal or hang from the brackets to provide end stops. Load capacity 10 kg. Max. 3 shelves/one side.

Cable channel PJK

May be fitted with a choice of components, ordered separately. All meet with CE requirements. 3 m cable is included. Supplied wired and ready for use.

COMPONENTS

- E1 Double socket
- E2 Switch
- E3 Automatic fuse 10 A
- E4 Aut./earth leakage switch 10 A/30 mA
- E5 Emergency-stop-switch
- E6 Data connector/shielded for Cat.6 cable
- E7 Data connector for Cat.5
- E8 Pneumatic, quick coupling 3/8"



Bin profile	profile
PBP 70 ESD	700 mm
PBP 100 ESD	1000 mm

Steel shelf	D x L
PSS 70 ESD	170 x 710 mm
PSS 100 ESD	170 x 1010 mm

Cable channel	profile
PJK 70	640 mm
PJK 100	940 mm

